



## Rotary Paddle Level Switch



[www.fine-tek.com](http://www.fine-tek.com)

# INTRODUCTION

---

## WORKING PRINCIPLE

The purpose of the rotary paddle level switch is to detect the presence of solid/powdery material in most kinds of tanks, bins and containers.

The unit is usually located through a bin wall at the top, middle or low level of a bin. During normal operation (no material present) a synchronous motor rotates the paddle at RPM. When this paddle rotation is impeded by material, surrounding the paddle, motor will stall and cause the Micro-switch to change state (indicating an alarm or control).

## APPLICATIONS

- Plastics and synthetics
- Chemicals and fertilizer
- Pharmaceuticals
- Food and Beverage,
- Agriculture and fodder mills/depots
- Cement as well as ceramics
- Power Plants
- Various Incinerators

## FEATURES

- Rugged sealing ring prevents dust from infiltrating the housing body along the shaft.
- Adjustable torque.  
If the rotary paddle encounters overloading, the motor will automatically shut down the motor to prevent damage to the inner mechanisms and extend motor life.
- Very suitable for small tanks and low density materials
- Adjustable and extendible shaft models available
- A wide variety of paddles are available

## BENEFITS

- Airtight sealed device.
- Outdoor and strenuous environment application
- Stable and reliable performance.
- Lightweight and easy to install
- Practically designed to allow maintenance, checks and replacement
- Not necessary to remove the complete set from the tank.

## STRUCTURE

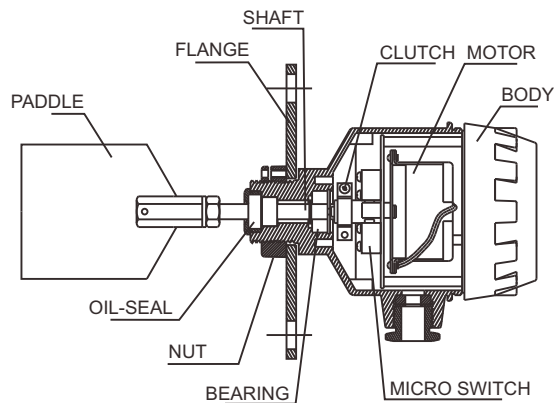

**STANDARD TYPE**

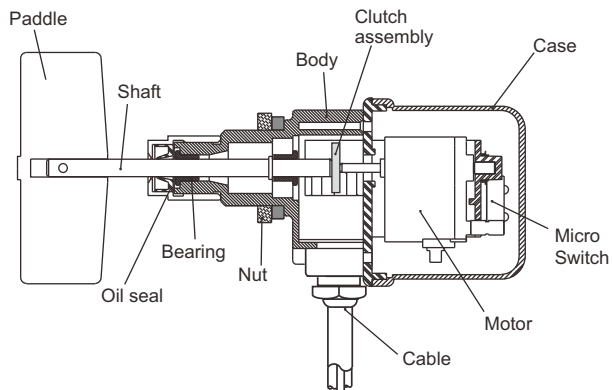

**MINI TYPE**

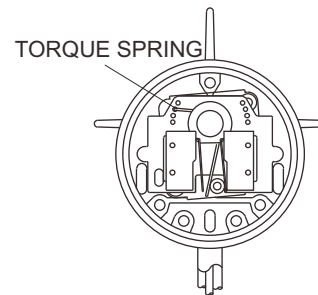

# WORKING PRINCIPLE & TORQUE ADJUSTING

## CONTROL SWITCH WORKING PRINCIPLE

1. A synchronous turning motor indicates the tank or container's material isn't obstructing the paddles, C & L [COM & NC] are connected.
2. When the material is obstructing the paddles, C&L [COM & NC] are disconnected, C&H [COM & NO] are connected and the motor's current is cut off.
3. When the material drops away from the paddles and the motor starts again C & L [COM & NC] connect and the cycle has begun once again.

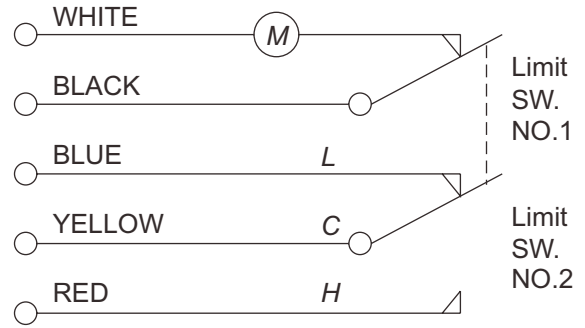

## TORQUE ADJUSTING MECHANISM

The torque spring is applied to adjust the shaft output torque. Default settings are "weak" and can be adjusted to the customer's target based on the tank contents and S.G. (special gravity) of the material.

Higher S.G. materials require stronger torque settings. Start with high settings and slowly release the torque force until the appropriate setting is found.

- Do not tamper with the spring as it may cause the Rotary Paddle to malfunction.

### Spring adjusting hole

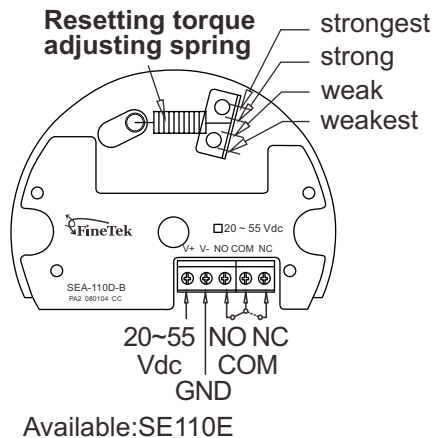
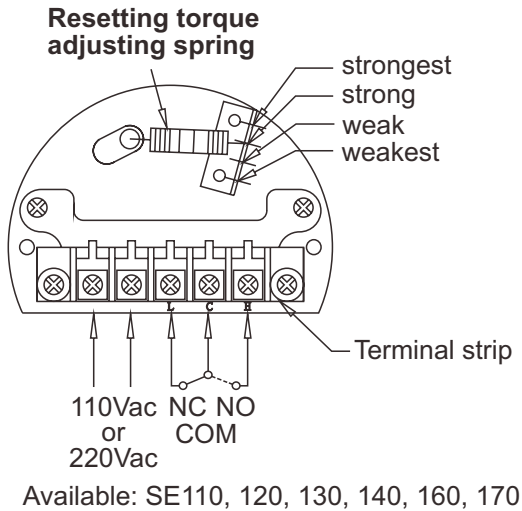
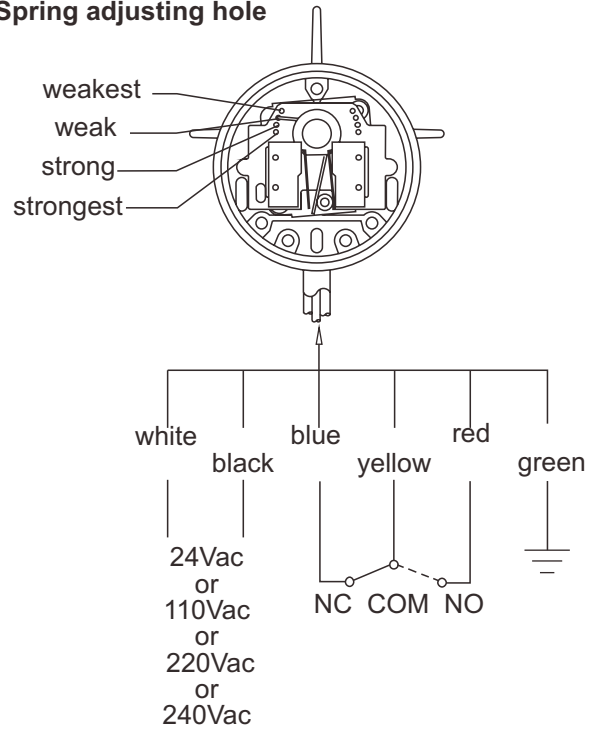

Available: SE180

# STANDARD MODELS

- **Power source** : (A)110Vac,(B)220Vac,(C)240Vac, (D)24Vac, 50/60Hz (E)24Vdc
- **Power consumption** : 3W, 11W(DC24V)
- **Contact capacity** : SPDT, 5A/250Vac
- **Rotary speed** : 1 R.P.M.
- **Insulation test voltage** : 2500V
- **Torque** : 0.5 ~1.0 kg-cm
- **Connection** : 1"PF screw or JIS 2-1/2" x 5kg/cm flange
- **Protection/ material** : IP65 / ADC-12
- **Conduit** : 1/2"PF
- **Specific gravity** : 0.5

## SCREW MODEL

### SE110 Series

- Horizontal mounting
- Operation Temperature (-20°C ~ 70°C)
- Weight: 1.2 kg

**SE110 Series**

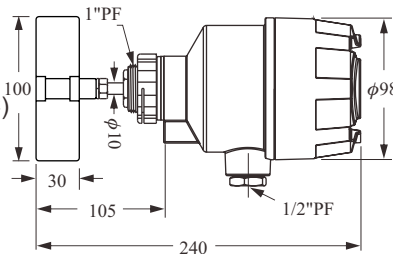

**SE111 Series**

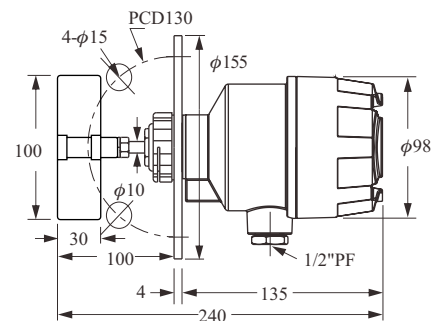

## FLANGE MODEL

### SE111Series

- Horizontal mounting
- Operation Temperature (-20°C ~ 70°C)
- Weight: 1.7 kg

## SHAFT PROTECTIVE TUBE MODEL

### SE120 Series

- Horizontal /Vertical mounting
- Operation Temperature (-20°C ~ 70°C)
- Weight: 1.2 kg
- Standard Length:
  - L--250mm (2.2 kg)
  - L--500mm (2.5 kg)
  - L--750mm (2.8 kg)
- Customized lengths available

**SE120 Series**

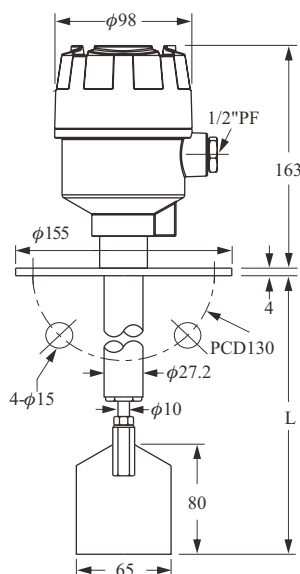

**SE130 Series**

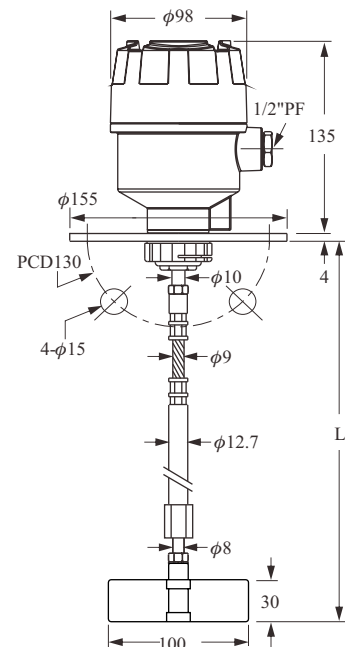

## SHAFT LENGTH ADJUSTABLE MODEL

### SE130 Series

- Vertical mounting
- Operation Temperature (-20°C ~ 70°C)
- Standard Length:
  - L-- 460~630mm (2.5 kg)
  - L-- 650~1000mm (2.8 kg)
  - L-- 760~1200mm (3.0 kg)
- Customized lengths available

# STANDARD MODELS

- **Power source** : (A)110Vac,(B)220Vac,(C)240Vac, (D)24Vac,50/60Hz (E)24Vdc
- **Power consumption** : 3W, 11W(DC24V)
- **Contact capacity** : SPDT, 5A/250Vac
- **Rotary speed** : 1 R.P.M.
- **Insulation test voltage** : 2500V
- **Torque** : 0.5 ~1.0 kg-cm
- **Connect** : 1"PF screw or JIS 2-1/2" × 5kg/cm<sup>2</sup> flange
- **Protection/ material** : IP65 / ADC-12
- **Conduit** : 1/2"PF
- **Specific gravity** : 0.5

## SE140A/B/C/D

### HI-TEMP TYPE

- Horizontal mounting
- Temp. (-20°C ~ 200°C)
- Weight: 2.1 kg

## SE140A/B/C/D Series

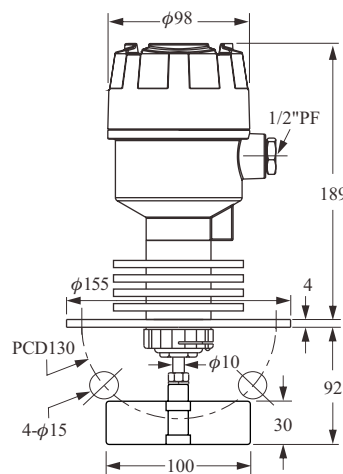

## SE141A/B/C/D Series

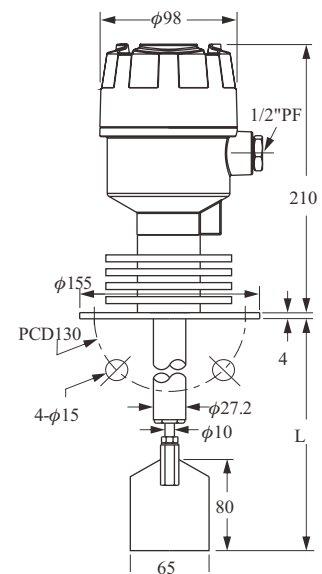

## SE141A/B/C/D/E

### HI-TEMP TYPE PROTECTIVE TUBE TYPE

- Horizontal /Vertical mounting
- Operation Temperature (-20°C ~ 200°C)
- Standard Length (option):  
L--250mm (2.6 kg)  
L--500mm (2.9 kg)  
L--750mm (3.2 kg)
- Special length is made by order

## SE146A/B/C/D/E

### HI-TEMP SHAFT LENGTH ADJUSTABLE TYPE

- Vertical mounting
- Operation Temperature (-20°C ~ 200°C)
- Standard Length (option):  
L- 450~630mm (3 kg)  
L- 650~1000mm (3.3 kg)  
L- 760~1200mm (3.5 kg)
- Special length is made by order

## SE146A/B/C/D/E Series

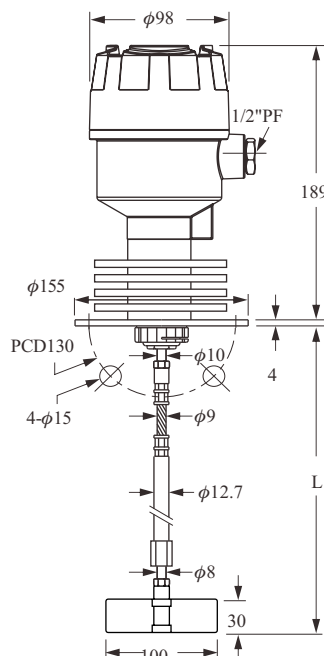

## SE160A/B/C/D/E Series

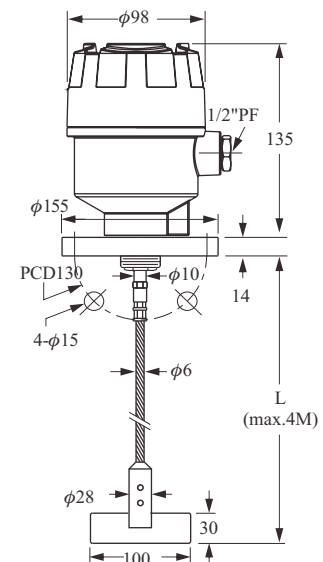

## SE160A/B/C/D/E CABLE WIRE TYPE

- Vertical mounting
- Operation Temperature (-20°C ~ 70°C)
- Standard Length (option):  
L-- 450mm (2.5 kg)  
L-- 650mm (2.8 kg)  
L-- 750mm (3 kg)
- Special length is made by order

# STANDARD MODELS

- **Power source** : (A)110Vac,(B)220Vac,(C)240Vac,  
(D)24Vac, 50/60Hz
- **Power consumption** : 1.5W
- **Contact capacity** : 3A/250Vac
- **Rotary speed** : R.P.M.
- **Protection/ material** : IP65 / PC

- **Temp.** : -20°C ~ 70°C
- **Cable length** : 30cm (available for custom length)
- **Torque** : 30 ~100 g-cm
- **Specific gravity** : 0.3

## CROSS-BLADE PADDLE

### SE280 Series

- Horizontal mounting
- Operation Temperature (-20°C ~ 70°C)
- Weight : 0.42 kg

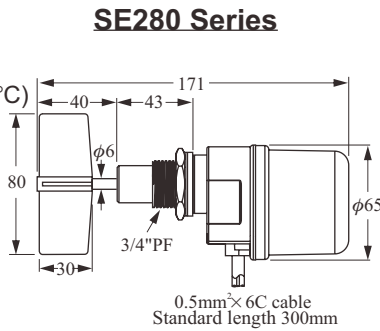

### SE280 CRI Series

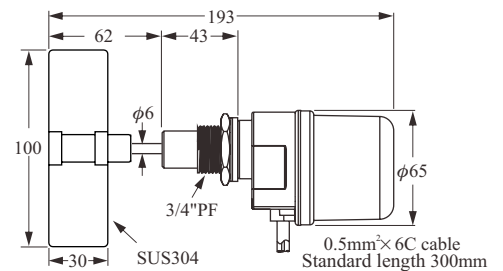

## RECTANGULAR 100x30 SUS304 PADDLE

### SE280 CRI Series

- Horizontal mounting
- Operation Temperature (-20°C ~ 70°C)
- Weight : 0.48 kg

### SE280 CRI Series

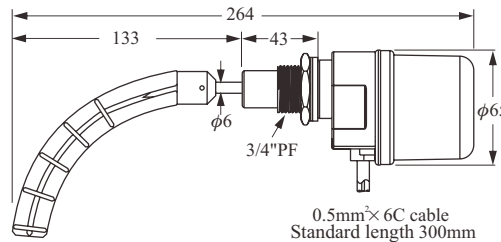

## SCIMITAR PADDLE

### SE280 CRH Series

- Horizontal mounting
- Operation Temperature (-20°C ~ 70°C)
- Weight : 0.42 kg

### SE282 CRI Series

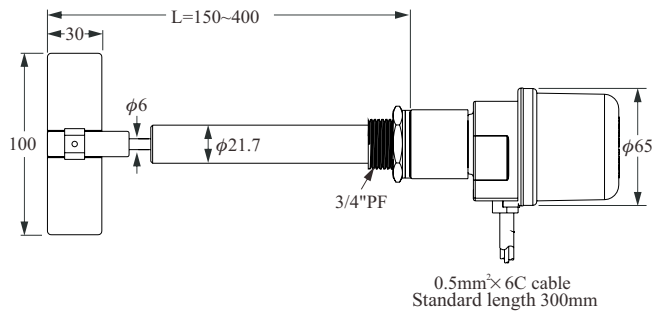

## SHAFT PROTECTION MODEL

### SE282 CRI Series

- Horizontal /Vertical mounting
- Operation Temperature (-20°C ~ 70°C)
- Weight : 0.42 kg

### SE284 CRI Series

## HI-TEMP SHAFT PROTECTION TUBE MODEL

### SE284 CRI Series

- Horizontal /Vertical mounting
- Operation Temperature (-20°C ~ 200°C)
- Weight : 0.142 kg

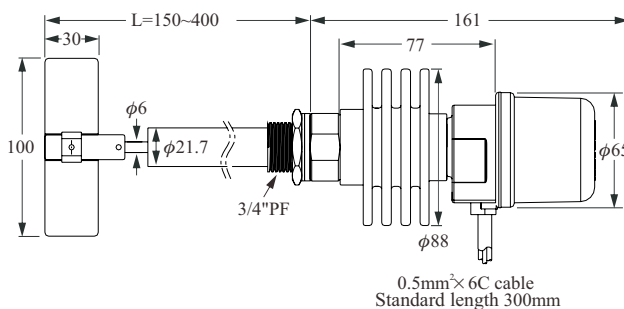

# MOUNTING EXAMPLES

Regular models such as the SE11 should be installed directly on the tank side.  
Mount at a 35° angle the blade through the tank opening or hole sliding the blade in first.

\* The SE170 series minimum hole size should be 95mm in diameter.  
The scimitar model is directly installed on the tank wall method as shown below.  
(Assuming an arc-shaped tank with a 3/4" connection) and then screwing it tight.

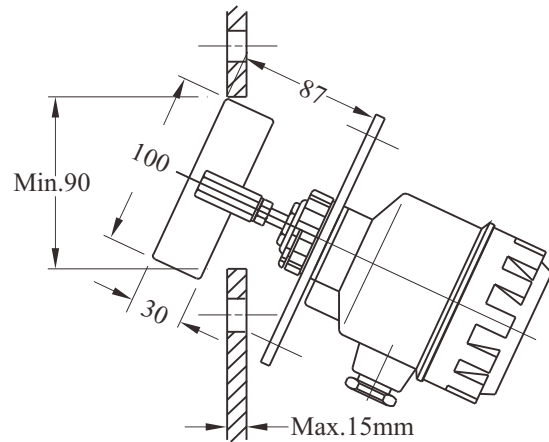
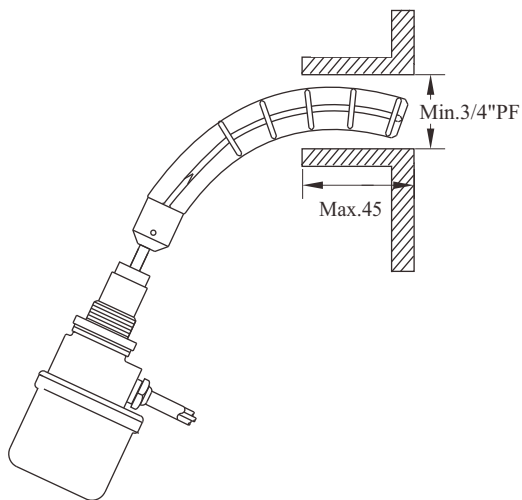

## INJECTION MOLDING MACHINES

Injection Molding Machine usually require the SE280.  
Install the Rotary Paddle through a 20mm diameter hole on the tank/silo.  
Remove the paddle from the device by taking out the fastening pin.  
Insert the SE280 through the mounting hole and tighten it.  
After which, secure the Paddle to the SE280 by locking it to the shaft with the pin.  
Keep in mind to 'widen' the opening of the pin in order to secure it.

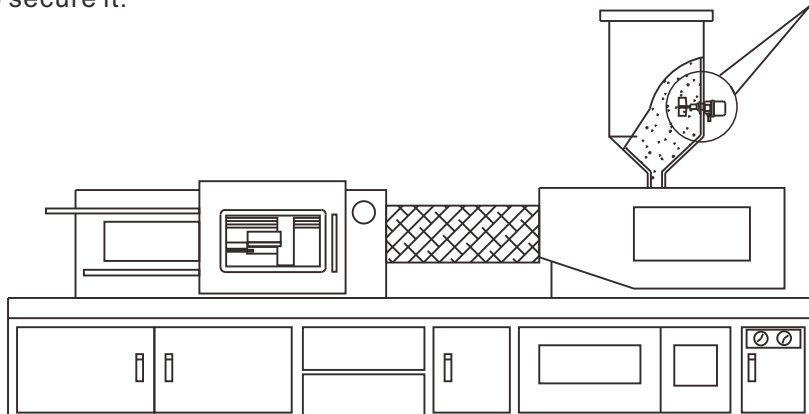
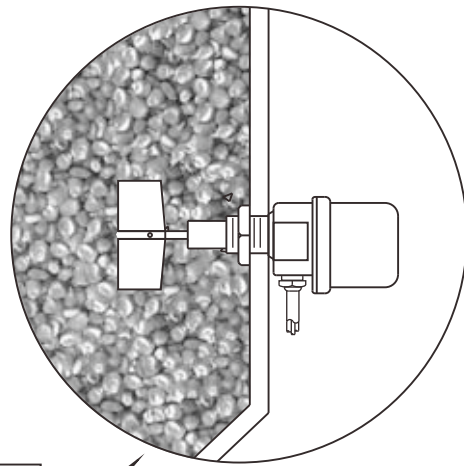

## EXAMPLES

---

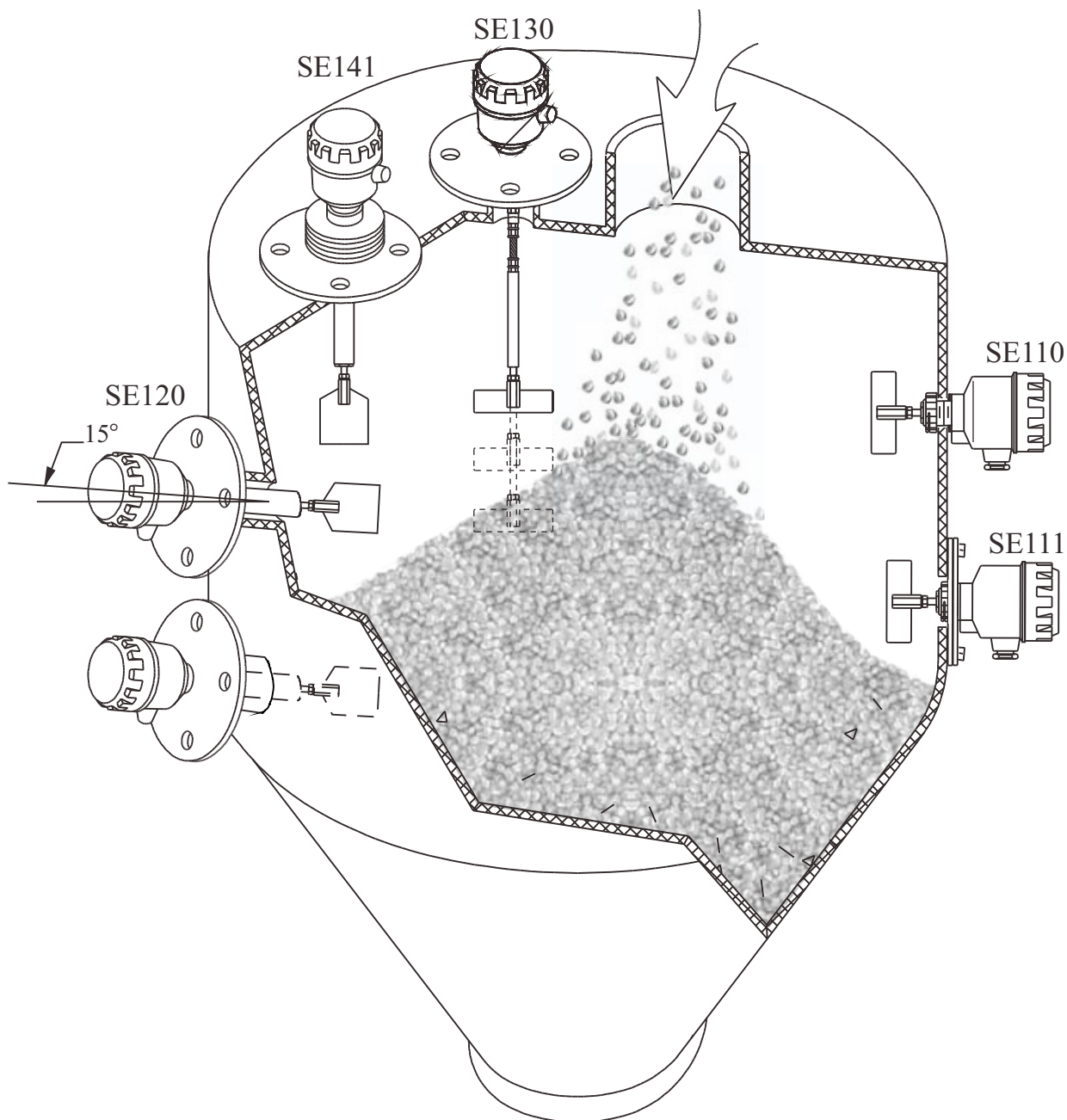

### INSTALLATION NOTICES

1. Side mount the sensor at a downward angle of 15° ~20° to decrease the material inflow impact.
2. For high temperature application (more than 70°C), please use the SE14□ Series.
3. For SE110~SE140 using a 1" inlet, please apply the scimitar model and screw directly.
4. For SE130, SE146 series have flexible and extendible shafts.
5. Please ensure the lead wire enters the housing from the bottom and the nuts are fastened to secure the device.





# EXPLOSION PROOF MODEL

NEPSI PROOF No.GYJ111214 Ex d IIC T3~T6  
 PTB PROOF No. 05 ATEX 1029 Ex II 2G Ex d IIB T6~T3 Gb  
 Ex II 2D Ex tb IIIC T85°C~T200°C Db IP65

- **Power source** : (A)110Vac, (B)220Vac, (C)240Vac, 50/60Hz
- **Power consumption** :3W
- **Contact capacity** : SPDT, 3A/250Vac
- **Rotary speed** : 1 R.P.M.
- **Insulation test voltage** : AC 1500V × 1minute
- **Torque** : 0.5 ~1.0 kg-cm
- **Connect** : 1"PF screw or flange 1"~6" 2-1/2" × 5kg/cm<sup>2</sup> (std.)
- **Housing material** : AL Alloy, ADC-12
- **Conduit** : 1/2" (std.) or 3/4"NPT
- **Specific gravity** : 0.5

## EXPLOSION PROOF CONNECTION MODEL SE170 series

- Horizontal mounting
- Temp. (-20°C ~ 70°C)

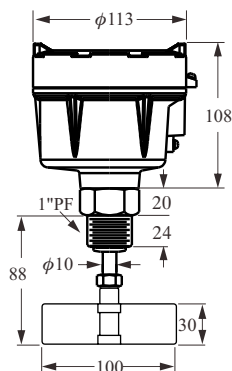

## EXPLOSION PROOF SHAFT PROTECTION MODEL SE172 series

- Horizontal /Vertical mounting
- Temp. (-20°C ~ 70°C)
- Standard Length (option):  
 L-- 250mm  
 L-- 500mm  
 L-- 750mm
- Customized lengths available

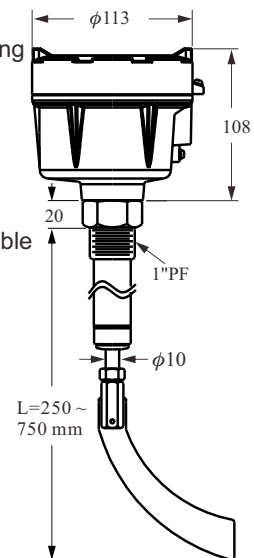

## EXPLOSION PROOF FLANGE MODEL SE171 series

- Horizontal mounting
- Temp. (-20°C ~ 70°C)

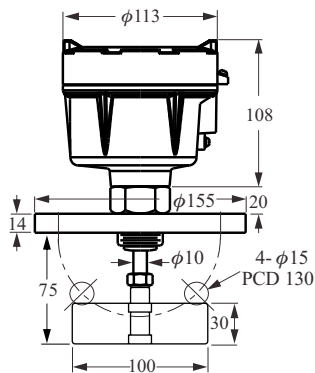

## EXPLOSION PROOF ADJUSTABLE SHAFT MODEL SE173 series

- Vertical mounting
- Temp. (-20°C ~ 70°C)
- Standard Length (option):  
 L-- 450 ~630mm  
 L-- 650 ~1000mm  
 L-- 760 ~1200mm
- Special length is made by order

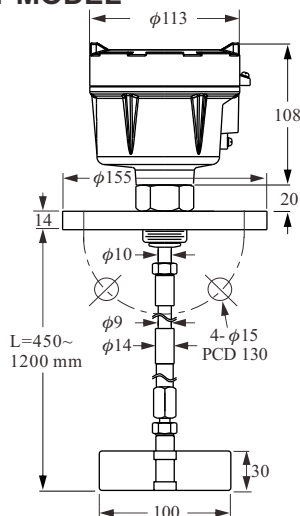

## EXPLOSION PROOF HI-TEMP MODEL SE174 series

- Horizontal mounting
- Temp. (-20°C ~ 200°C)

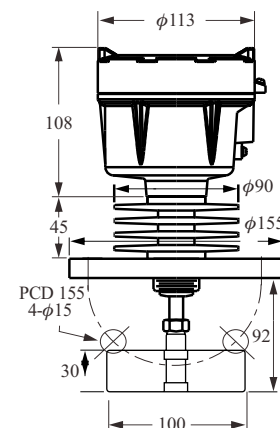

# EXPLOSION PROOF MODEL

NEPSI PROOF No. GYJ111214 Ex d IIC T3~T6  
 PTB PROOF No. 05 ATEX 1029  $\text{Ex d IIB T6~T3 Gb}$   
 $\text{Ex II 2D Ex tb IIIC T85}^\circ\text{C~T200}^\circ\text{C Db IP65}$

## EXPLOSION PROOF HI-TEMP SHAFT PROTECTIVE TUBE MODEL SE175

- Horizontal /Vertical mounting
- Temp. (-20°C ~ 200°C)
- Special length is made by order

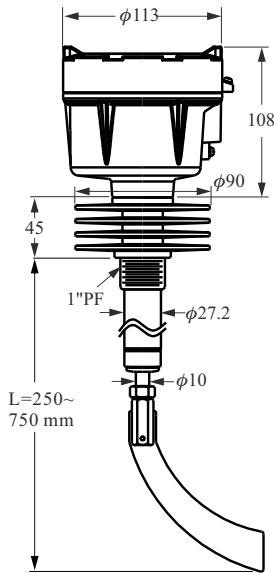

## EXPLOSION PROOF HI-TEMP ADJUSTABLE SHAFT MODEL SE176

- Vertical mounting
- Temp. (-20°C ~ 200°C)
- Special length is made by order

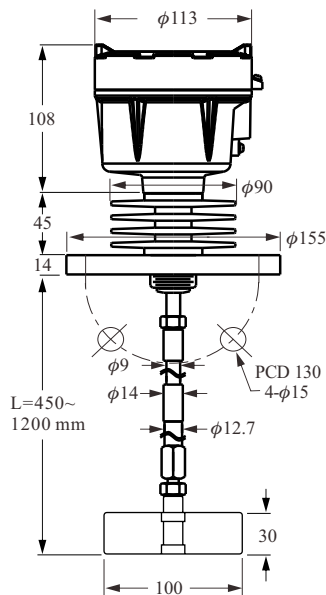

## EXPLOSION PROOF CABLE WIRE MODEL SE177

- Vertical mounting
- Temp. (-20°C ~ 70°C)
- Special length is made by order

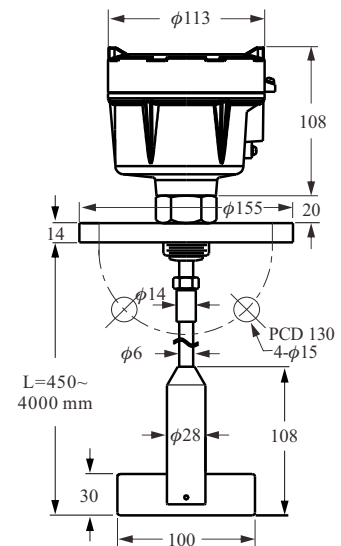

## ■ Paddle Introduction

	<p>(A) 100x30 (WxH), Min. fixed hole diameter size φ90mm.</p>		<p>(E) 50x30 (WxH), Suitable for high S.G. raw materials. Use a small size paddle to decrease the impact of material falling directly on paddle.</p>
	<p>(B) 65x80 (WxH), Directly mounted into 2" fixed hole.                  (C) 65x120 (WxH), Directly mounted into 2" fixed hole.                  (D) 80x80 (WxH)</p>		<p>(F) Scimiter model paddle, Screw tightly on the 1" diameter fixed hole, It is easier to mount and dismount.</p>

# HOW TO ORDER

SE1       (    )

**MODEL NO.** \_\_\_\_\_

- |                                   |   |
|-----------------------------------|---|
| 70: Screw model                   | 74: Hi-temp model                         |
| 71: Flange model                  | 75: Hi-temp shaft protective tube model   |
| 72: Shaft protective tube model   | 76: Hi-temp shaft length adjustable model |
| 73: Shaft length adjustable model | 77: Cable wire model                      |

**VOLTAGE** \_\_\_\_\_

A : 110Vac B : 220Vac C : 240Vac

**MOUNTING** \_\_\_\_\_

Size for flange or screw		Specification	
C: 3/4"	I: 4"	M: 5kg/cm <sup>2</sup>	Z: PN40
D: 1"	J: 5"	N: 10kg/cm <sup>2</sup>	Q: PT
E: 1-1/2"	K: 6"	O: 150 Lbs	R: PF (G)
F: 2"	S: Others	P: 300 Lbs	T: BSP
G: 2-1/2"	3: 1-1/4"	W: PN10	U: NPT
H: 3"		X: PN16	S: Others
		Y: PN25	

**PADDLE SHAPES** \_\_\_\_\_

- A : 100x30 (WxH)
- B : 65x80 (WxH)
- C : 65x120 (WxH)
- D : 80x80 (WxH)
- E : 50x30 (WxH)
- F : Scimitar
- S : Others

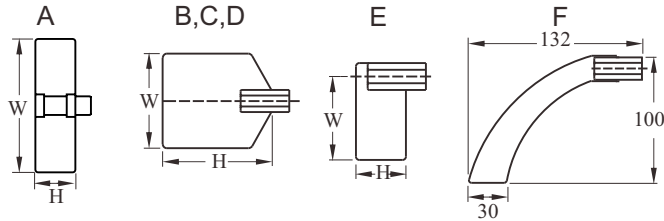

**LENGTH (mm)** \_\_\_\_\_

- 0500: below 500mm
  - 1000: 501~1000mm
  - 1500: 1001~1500mm
  - ⋮
- ※ 500mm per Unit  
 ※ The total length of item will be allowed a margin of error of 6mm.

**\* Note**

1. Check the voltage 24Vac, 110Vac, 220Vac or 240Vac, 50/60 Hz.
2. Check the side or top mounting.
3. Check the material specific gravity (S.G.) value.
4. If blockages are frequent or vibrating motors are installed onto the tank wall, our SA140 capacitance level sensor is more suitable.
5. Check whether the rotary paddle can fit through the flange inlet or from the inside of the tank

# EXAMPLES-OF-TANK-MOUNTING

- [FC/FD] Mini Float/Magnetic Float Level Switch
- [FG] Magnetic Float Level Transmitter
- [FF] Side Mounting Float Switch
- [FA/FB] Cable Float Level Switch
- [SP] Thermal Dispersion Flow Switch
- [SF] Paddle Flow Switch
- [SD] Optical Level Switch
- [SE] Rotary Paddle Level Switch
- [SA] Capacitance Level Switch
- [EC] Pressure Level Transmitter
- [SC] Vibrating Probe Level Switch
- [SC] Tuning Fork Level Switch
- [EB] RF-Capacitance Level Transmitter
- [SB] RF-Capacitance / Admittance Level Switch
- [EG] Magnetostrictive Level Transmitter
- [EF] By-Pass Level Transmitter
- [MEF] Mini By-Pass Level Transmitter
- [EA] Ultrasonic Level Transmitter
- [JFR] FMCW Radar Level Transmitter
- [EE] Electromechanical Level Measuring System
- [ED] Speed Monitor
- [SRT/SRS] Conveyer Belt Misalignment Switch & Safety Cable Pull Switch
- [PB/PM] Microprocessor Based Bargraphic Display Scaling Meter
- [BRD/AE] Valve and Controller for Dust Collector System
- [BAS/BAH/BVP] Air Hammer
- [BVK/BVR/BVT] Pneumatic Vibrator

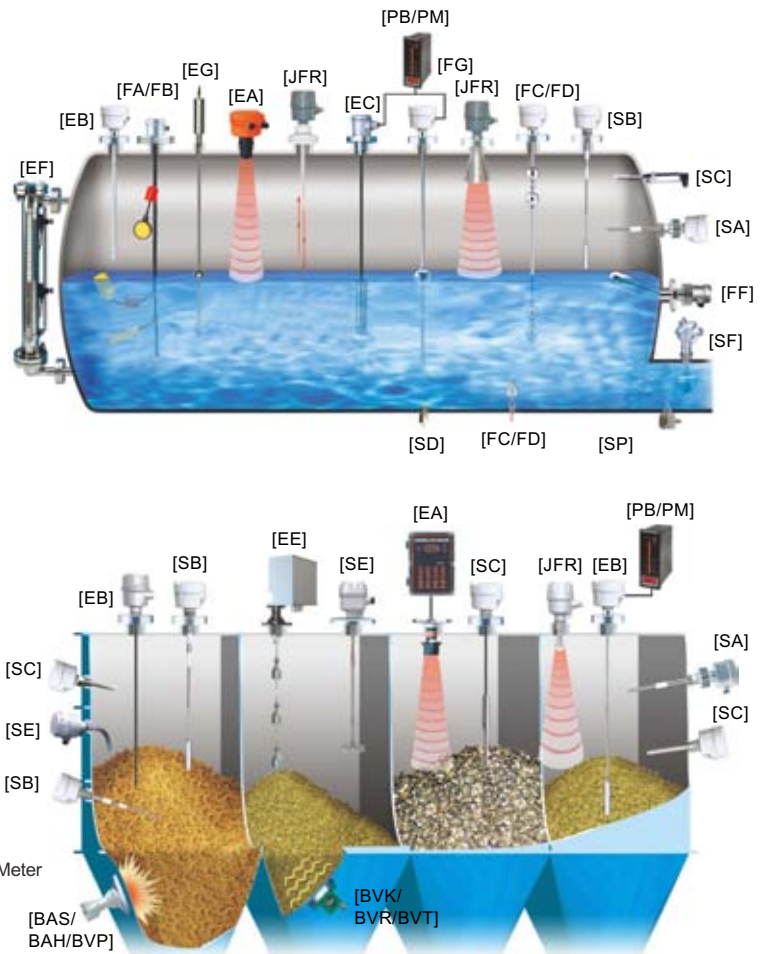

## FineTek Co., Ltd.

No.16, Tzuchiang St., Tucheng Industrial Park, New Taipei City 236, Taiwan.  
 TEL: 886 2 2269 6789 FAX: 886 2 2268 6682  
 Email: info@fine-tek.com http://www.fine-tek.com

## Fine automation (ShangHai) Co., Ltd.

No.451 DuHui Rd, MinHang District, Shanghai, China 201109  
 TEL: 86 21 6490 7260 FAX: 86 21 6490 7276  
 Email: info.sh@fine-tek.com http://www.fineautomation.com.cn

## FineTek Pte Ltd.

No. 60 Kaki Bukit Place, #07-06 Eunos Techpark 2  
 Lobby B, Singapore 415979  
 TEL: 65 6452 6340 FAX: 65 6734 1878  
 Email: info.sg@fine-tek.com

## FineTeK GmbH

Frankfurter Str. 62, OG D-65428 Ruesselsehim, Germany  
 TEL: 49 6142 17608 0 FAX: 49 6142 17608 20  
 Email: info@fine-tek.de

## Aplus Finetek Sensor inc.

355 S. Lemon Ave, Suite D, Walnut, CA 91789  
 TEL: 1 909 598 2488 FAX: 1 909 598 3188  
 Email: peter.wu@aplusfine.com http://www.aplusfine.com



Distributor: